

PRESSURE SWITCHES

PS83

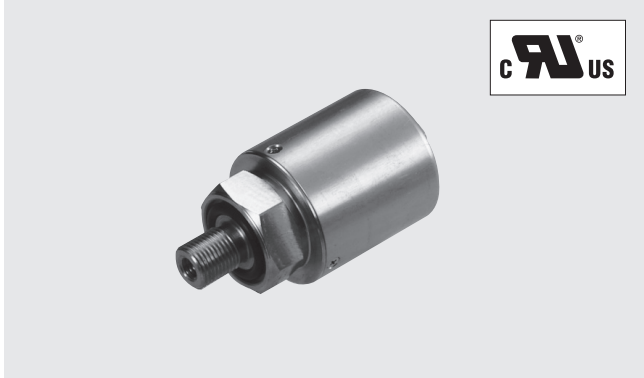

FEATURES

- Solidstate pressure switch with no mechanical moving parts
- High corrosion resistance by double diaphragm structure
- Two pressure setting points
- Wide pressure medium compatibility
- Can be attached with a *VCR® fitting

INTERNAL STRUCTURE (G 1/8)

Part name		Material
①	Fitting	SUS 316L
②	“O” ring (P15 or P12.5)	Fluoro-rubber
③	Housing	Aluminum
④	Compensation resistor board	Ceramic
⑤	Sealed liquid	Silicone oil

MODEL NUMBER DESIGNATION

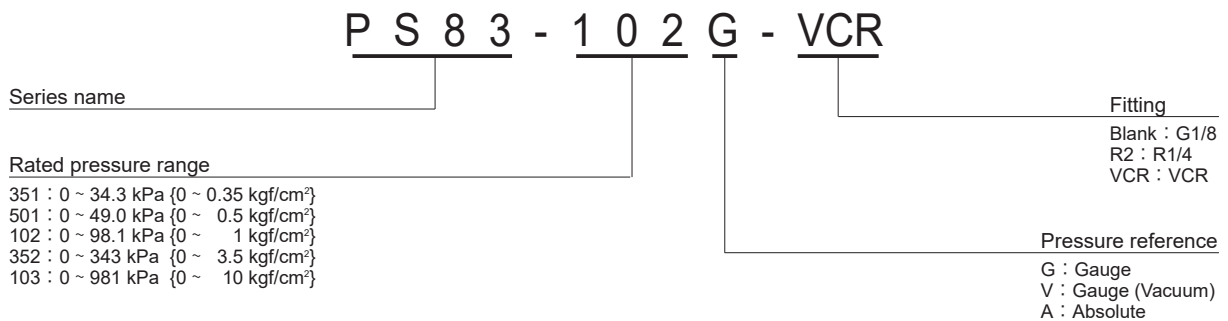

※ Please refer to the LIST OF MODEL NUMBERS when placing orders.

※ VCR® is a registered trade name of Cajon Co. CAJON® is a registered trade name of Swagelok Co.

Note: For handling of VCR fittings, please contact a service center of Swagelok Co.

PS83 PRESSURE SWITCHES

LIST OF MODEL NUMBERS

Pressure reference		Gauge					Absolute	
Pressure port	Rated pressure range kPa {kgf/cm ² }	0 ~ 49.0 {0 ~ 0.5}	0 ~ 98.1 {0 ~ 1}	0 ~ 343 {0 ~ 3.5}	0 ~ 981 {0 ~ 10}	0 ~ - 98.1 {0 ~ - 1}	0 ~ 34.3 {0 ~ 0.35}	0 ~ 98.1 {0 ~ 1}
G 1/8(PF 1/8)		PS83-501G	PS83-102G	PS83-352G	PS83-103G	PS83-102V	PS83-351A	PS83-102A
R 1/4 (PT 1/4)		PS83-501G-R2	PS83-102G-R2	PS83-352G-R2	PS83-103G-R2	PS83-102V-R2	PS83-351A-R2	PS83-102A-R2
VCR(9/16-18UNF)		PS83-501G-VCR	PS83-102G-VCR	PS83-352G-VCR	PS83-103G-VCR	PS83-102V-VCR	PS83-351A-VCR	PS83-102A-VCR

※ Verify the above model numbers when placing orders.

STANDARD SPECIFICATIONS

● Unless otherwise specified, the specs are defined at an ambient temperature of 25 ± 5 °C and excitation voltage of 12 VDC.

Item	Model number	PS83						
		501G	102G	102V	352G	103G	351A	102A
General specifications	Pressure reference	Gauge					Absolute	
	Rated pressure range kPa {kgf/cm ² }	49.0 {0.5}	98.1 {1}	- 98.1 {-1}	343 {3.5}	981 {10}	34.3 (abs) {0.35}	98.1 (abs) {1}
	Maximum pressure kPa {kgf/cm ² }	98.1 {1}	196 {2}		686 {7}	1961 {20}	103 (abs) {1.05}	196 (abs) {2}
	Break-down pressure kPa {kgf/cm ² }	147 {1.5}	294 {3}		1030 {10.5}	2942 {30}	147 (abs) {1.5}	294 (abs) {3}
	Operating temp. range °C	- 20 ~ 70						
	Compensated temp. range °C	0 ~ 50						
	Operating humidity %RH	35 ~ 85 (No condensation)						
	Storage temp. °C	- 20 ~ 70 (Atmospheric pressure humidity 65 %RH maximum)						
	Pressure medium	Corrosive gases/liquids compatible with SUS 316L ※ 1						
	Insulation resistance MΩ minimum	100 (500 VDC)						
	Dielectric strength	500 VAC, 60 s (Leakage current 1mA maximum)						
	Sealed liquid	Silicone oil						
	Pressure port	G 1/8 (PF 1/8) ※ 2, R 1/4 (PT 1/4), 1/4 VCR®						
	Net weight g	Approx. 140						
Power	Supply voltage VDC	12 ~ 24 ± 10 %						
	Ripple content maximum	10 % (P-P) maximum						
	Consumption current maximum	20 mA						

※ 1 : Also compatible with SUS316 in case of PS83- □□□□ -VCR.

※ 2 : In case of G 1/8 type, An "O" ring is supplied as accessory.
(P15 for positive press., P12.5 for negative / absolute press.)

PS83

PRESSURE SWITCHES

Item	Model number	PS83							
		501G	102G	102V	352G	103G	351A	102A	
Switch output	No. of output	2							
	Output interface	NPN open collector output							
	Setting method	Adjustable by VR							
	Adjustable range	Zero through rated pressure, minimum							
	Display	Red LED (lighted when output is ON.)							
	Accuracy (Reference temp.: 25 °C)	% F.S.	± 3						
	Hysteresis	% F.S. maximum	2						
	Switching capacity		30 VDC 80 mA maximum						
	Residual voltage	V maximum	0.8						
	Response	ms	Approx. 2						

ENVIRONMENTAL CHARACTERISTICS

Test item	Test conditions (At 25 ± 5 °C)	Permissible change
Vibration	10 ~ 500 Hz, 1.5 mm maximum/98.1 m/s ² , 3 directions for 2 hours each	Switch output setting: ± 1 %F.S. maximum
Shock	490 m/s ² , 3 directions for 3 times each	
Pressure cycling	0 ~ Rated pressure, 10 ⁶ cycles	
Moisture resistance	40 °C, 90 ~ 95 %RH, 240 hrs.	

INTERNAL ELECTRICAL SCHEMATICS SWITCHING OPERATION

● PS83-***G

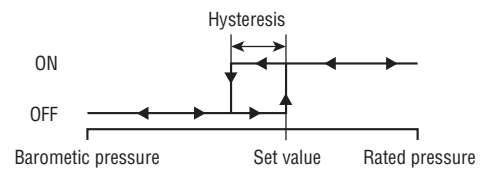
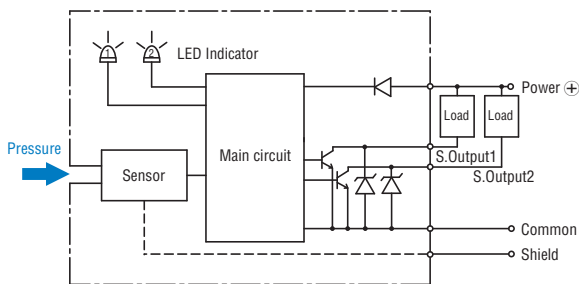

● PS83-102V

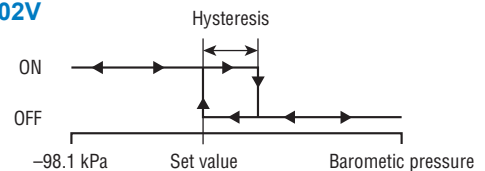

● PS83-***A

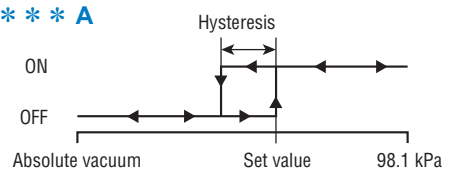

※ 2 switches show same performance.

PS83 PRESSURE SWITCHES

OUTLINE DIMENSIONS

Unless otherwise specified, tolerance : ± 0.5(Unit: mm)

PS83 (G 1/8 type)

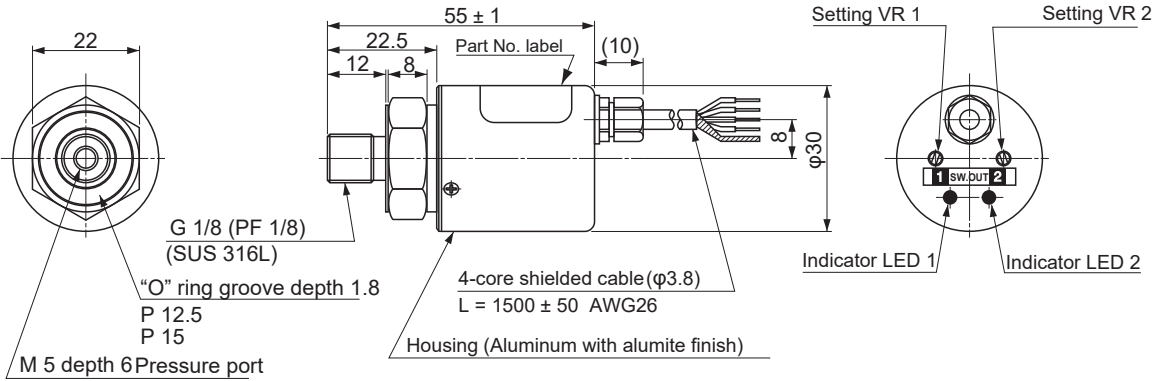

PS83 (R1/4 type)

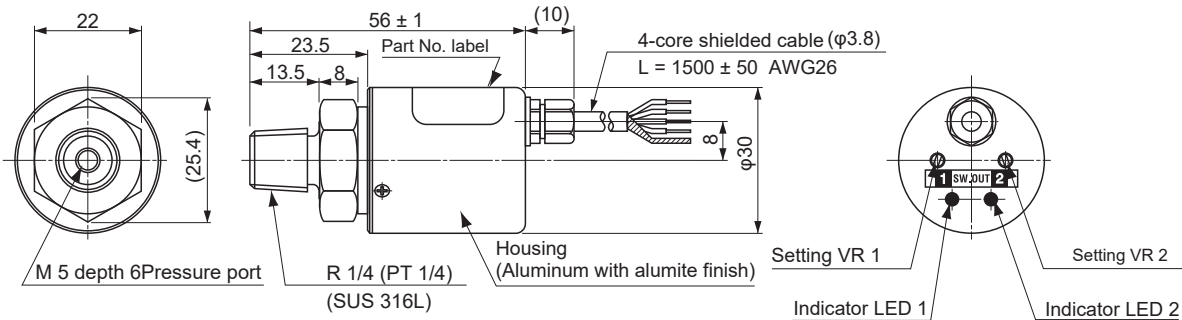

PS83 (VCR type)

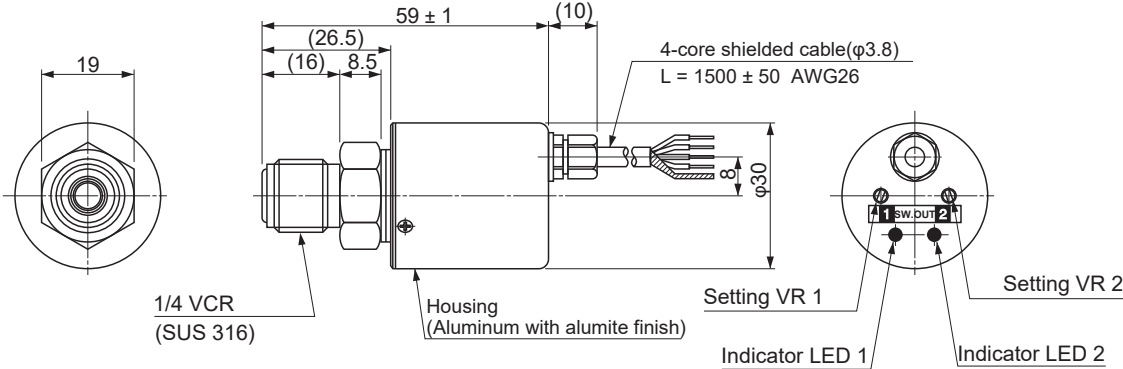

Wire color	Connection
Red	Power ⊕
Green	Output 1
White	Output 2
Black	Common
Shield	Fitting