

The Rotary Encoder series includes optical and magnetic encoders. Optical models run from ϕ 12 to ϕ 30 and include small, light weight, and low cost models, as well as high resolution, and manual setting models. These encoders can be used to sense the angle, size and rotation speed of industrial equipment, including industrial robots, numerically controlled (NC) machine tools, elevators, production equipment, terminals at financial institutions, computer peripheral equipment, etc. They can also be used as manual setting encoders for digital equipment, such as measuring, communications and medical equipment.

ROTARY ENCODERS OPERATING PRINCIPLES

■ BASIC CONSTRUCTIONS

● Optical encoders

The light from the LED which passes through the slit of the rotating disk actuates the photo-sensor. The output of the photo-sensor which is quasi-sinusoidal is shaped into square wave by the voltage comparator and fed into a logic circuit.

● Magnetic encoders

Principle structure is composed of magnetic sensor and magnetic drum (corresponding to LED and photo-sensor in an optical encoder).

Without power consuming LED, total dissipation power of the magnetic encoder is far less than that optical encoder.

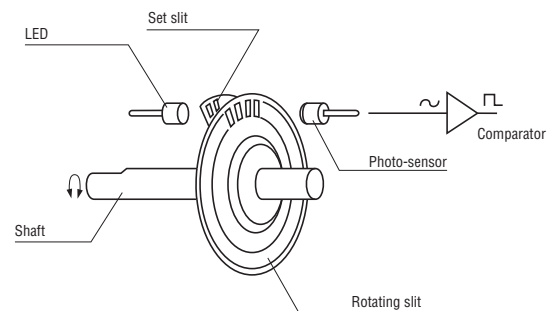

Fig. 1

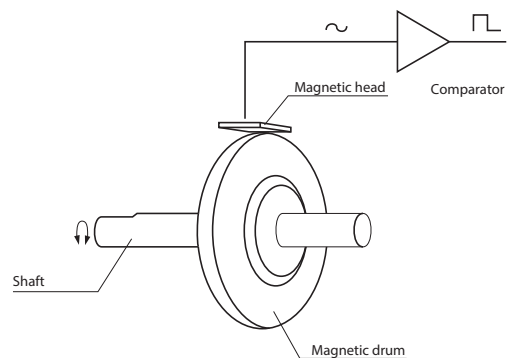

Fig. 2