

OPTICAL ENCODERS

RE12

FEATURES

- ϕ 12 mm, High resolution up to 300 P/R
- Cost effective
- Two bearing types to choose from;
Sleeve bearing or ball bearing
- Low torque, low inertia
- RoHS compliant

RoHS compliant

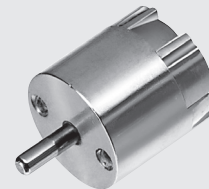

PART NUMBER DESIGNATION

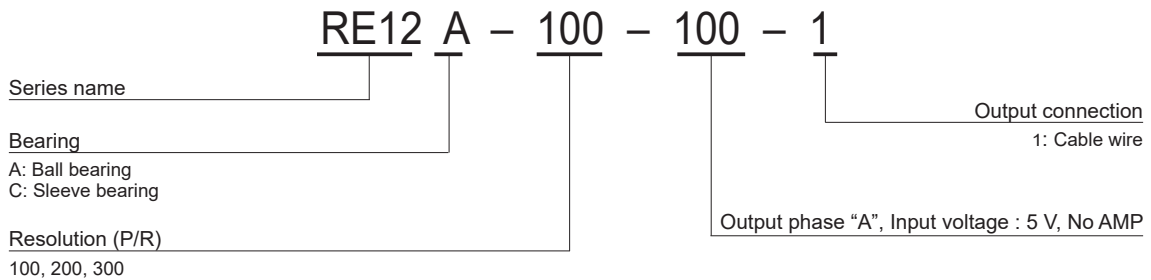

LIST OF PART NUMBERS

Bearing	Resolution	Part number
Ball Bearing	100 P/R	RE12A-100-100-1
	200 P/R	RE12A-200-100-1
	300 P/R	RE12A-300-100-1
Sleeve Bearing	100 P/R	RE12C-100-100-1
	200 P/R	RE12C-200-100-1
	300 P/R	RE12C-300-100-1

※ Verify the above part numbers when placing orders.

STANDARD SPECIFICATIONS

ELECTRICAL CHARACTERISTICS

Item	Resolution	100 • 200 P/R	300 P/R
Photo-sensor maximum current		50 mA maximum (at 25 °C)	
Output wave form		Quasi-sinusoidal	
Output signal	※1	150 mVp-p minimum	100 mVp-p minimum
Output signal amplitude variation	※2	40 % maximum	50 % maximum
Light source		LED	

※ 1 : Measured at CP1 as per the Fig. A of 'MEASUREMENT CIRCUIT' on the following page. (3 kHz)

※ 2 : Measured at CP2 as per the Fig. A of 'MEASUREMENT CIRCUIT' on the following page. (3 kHz)

Environmental characteristics

Operating temp. range	-10 ~ 50 °C
Storage temp. range	-20 ~ 80 °C
Protection grade	IP40

RELIABILITY TEST

The output shall satisfy the criteria below after the following tests.

Test item		Test conditions	
Vibration	Power OFF	Amplitude : 1.52 mm or 98.1 m/s ² (10 G) whichever is smaller. 10 ~ 500 Hz excursion 5 min/cycle, 1 hour each for X, Y, Z, directions.	
Shock	Power OFF	1 time each in 6 directions (X, Y, Z) at 490 m/s ² (50 G), 11 ms.	
High temperature exposure	Power OFF	80 °C 96 h	(To be measured after leaving samples for 1 h at normal temperature and humidity after the test.)
	Power ON	50 °C 96 h	
Low temperature exposure	Power OFF	- 20 °C 96 h	
	Power ON	- 10 °C 96 h	
Humidity	Power OFF	To be measured after wiping out moisture and leaving samples for 1 h at normal temperature and humidity after the test.	
Thermal shock	Power OFF	To be done 10 cycles with the following condition (To be measured after leaving samples for 1 h at normal temperature and humidity after the test.) 80 °C 1 h, - 20 °C 1 h	

Criteria

	100 • 200 P/R	300 P/R	Measurement point
Output signal level	S min ≥ 0.13 V	S min ≥ 0.08 V	CP1 in 'MEASUREMENT CIRCUIT'
Amplitude variation	(S max / S min - 1) × 100 ≤ 45 %	(S max / S min - 1) × 100 ≤ 55 %	CP2 in 'MEASUREMENT CIRCUIT'

Mechanical characteristics

Starting torque	Ball bearing	0.05 mN·m {0.5 gf·cm} maximum
	Sleeve bearing	0.4 mN·m {4 gf·cm} maximum
Inertia		0.01 g·cm ² maximum
Shaft loading	Radial	1.96 N {200 gf} maximum
	Axial	4.9 N {500 gf} maximum
Net weight		Approx. 10 g

Output signal level & Amplitude variation

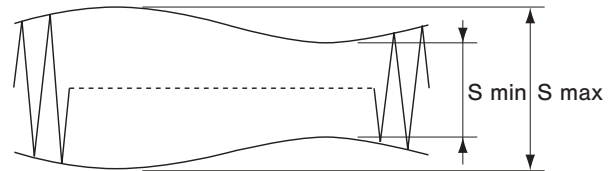

※ Output signal level :

100, 200 P/R Smin ≥ 0.15 V, 300 P/R Smin ≥ 0.10 V

Amplitude variation :

100, 200 P/R (Smax/Smin-1) × 100 ≤ 40 %

300 P/R (Smax/Smin-1) × 100 ≤ 50 %

RE12

OPTICAL ENCODERS

OUTLINE DIMENSIONS

Unless otherwise specified, tolerance : ± 0.4 (Unit : mm)

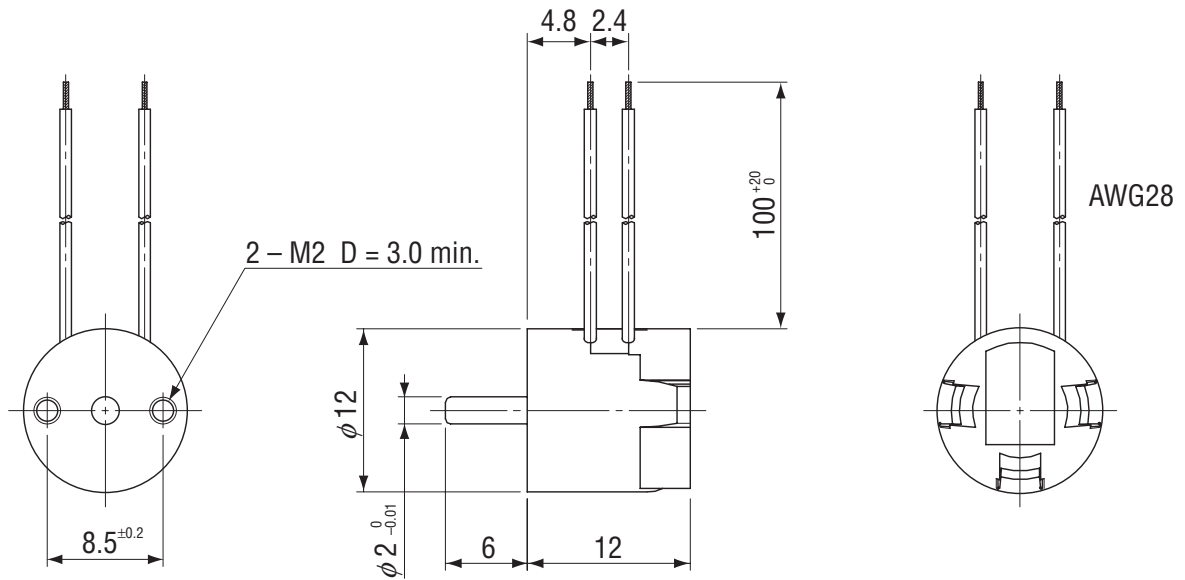

INTERNAL CIRCUIT

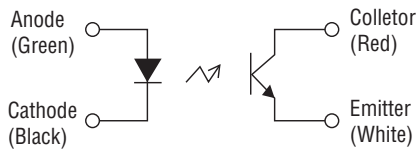

MEASUREMENT CIRCUIT

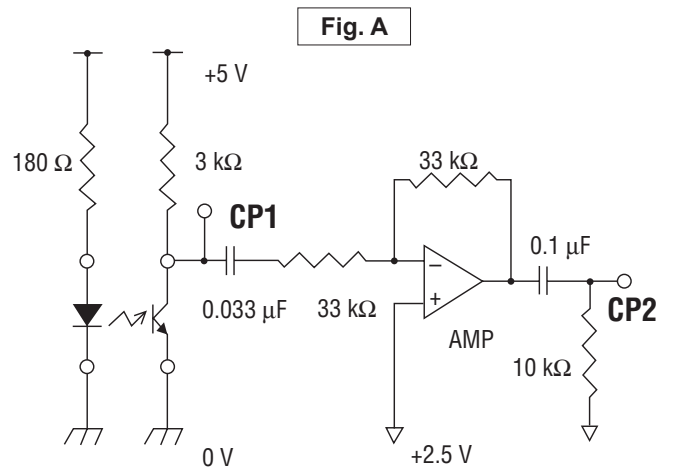

Frequency characteristics : 3 kHz (at constant speed)